

0251 Double ring spanner, open, DIN 3118, 8x10 mm, MATADOR item no.: 02510810

0251 Double ring spanner, open, DIN 3118, 8x10 mm, MATADOR item no.: 02510810

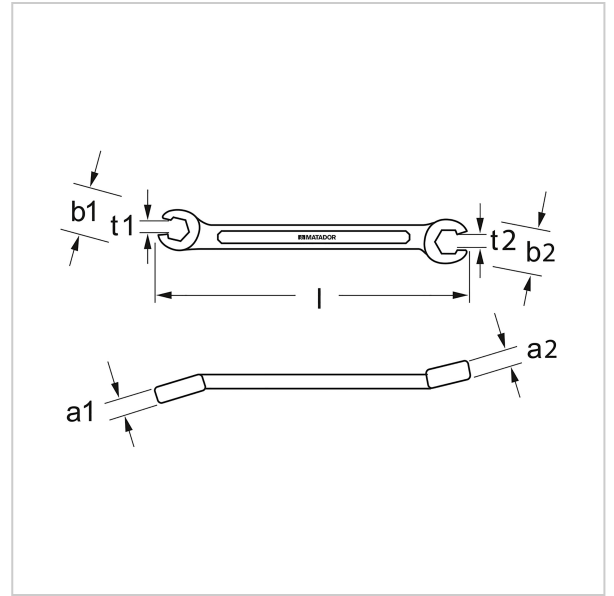
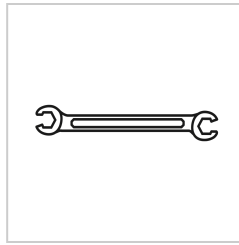

Beschreibung:

Double ring spanner, open, metric.

For union nuts and bolts on pipes, also ideal for brake lines. Drop-forged with reinforced ring. Heads angled 15°, opening 30° offset and slotted. With hexagonal ring. Made of chrome vanadium steel (**31CrV3**), with matt chrome-plated surface for pleasant grip even with oily hands.

Technische Daten

Manufacturer-Number:	02510000M
Width:	80 mm
Height:	10 mm
Length:	140 mm
Weight:	0.047 kg